



Power Factor in Electrical Energy Management

Office: (031) 903 1898
Fax: 086 402 8682
Mail: admin@enisave.co.za
Web: www.enisave.co.za

Power Factor in Electrical Energy Management

Content

What is Power Factor?

Power factor is the percentage of electricity that is being used to do useful work. It is defined as the ratio of 'active or actual power' used in the circuit measured in watts or kilowatts (W or KW), to the 'apparent power' expressed in volt-amperes or kilo volt-amperes (VA or KVA).

$$\text{Power factor} = \frac{\text{Active Power}}{\text{Apparent Power}} \text{ or } \frac{W}{VA}$$

The apparent power also referred to as total power delivered by utility company has two components.

- 1) 'Productive Power' that powers the equipment and performs the useful work. It is measured in KW (kilowatts)
- 2) 'Reactive Power' that generates magnetic fields to produce flux necessary for the operation of induction devices (AC motors, transformer, inductive furnaces, ovens etc.). It is measured in KVAR (kilovolt-Ampere-Reactance).

Reactive Power produces no productive work. An inductive motor with power applied and no load on its shaft should draw almost nil productive power, since no output work is being accomplished until a load is applied. The current associated with no-load motor readings is almost entirely "Reactive" Power. As a load is applied to the shaft of the motor, the "Reactive" Power requirement will change only a small amount. The 'Productive Power' is the power that is transferred from electrical energy to some other form of energy (i.e. such as heat energy or mechanical energy). The apparent power is always in excess of the productive power for inductive loads and is dependent on the type of machine in use.

The working power (KW) and reactive power (KVAR) together make up apparent power, which is measured in kilovolt-amperes (KVA). Graphically it can be represented as:

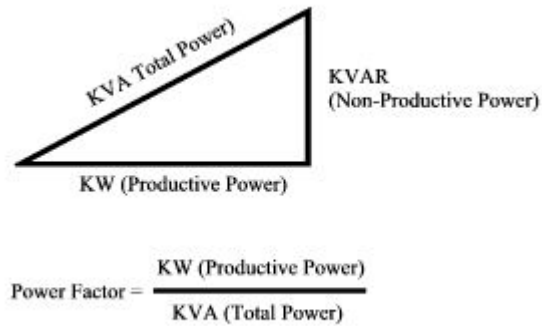

The cosine of the phase angle ϕ between the KVA and the KW components represents the power factor of the load. KVAR represents the non-productive reactive power and ϕ is lagging phase angle.

The Relationship between KVA, KW and KVAR is non-linear and is expressed $KVA^2 = KW^2 + KVAR^2$

A power factor of 0.72 would mean that only 72% of your power is being used to do useful work. Perfect power factor is 1.0, (unity); meaning 100% of the power is being used for useful work.

Understanding Power Factor?

Any industrial process using electric motors (to drive pumps, fans, conveyors, refrigeration plant etc.) introduces inefficiencies into the electricity supply network by drawing additional currents, called "inductive reactive currents".

Although these currents produce no useful power, they increase the load on the supplier's switchgear & distribution network and on the consumer's switchgear & cabling. The inefficiency is expressed as the ratio of useful power to total power (KW/KVA), known as Power Factor. The typical 'un-corrected power factor' by different sectors of industry are as follows:

Typical Un-improved Power Factor by Industry

Industry	Power Factor
Auto Parts	75-80
Brewery	75-80
Cement	80-85
Chemical	65-75
Coal Mine	65-80
Clothing	35-60
Electroplating	65-70
Foundry	75-80
Forging	70-80
Hospital	75-80
Machine Manufacturing	60-65
Metalworking	65-70
Office Building	80-90
Oil field Pumping	40-60
Paint Manufacturing	65-70
Plastic	75-80
Stamping	60-70
Steel Works	65-80
Tool, dies, jigs industry	65-75

Typical uncorrected industrial power factor is 0.8. This means that a 1MVA transformer can only supply 800KW or that a consumer can only draw 80 useful Amps from a 100Amp supply. To put it the other way, a 3-phase 100KW load would draw 172A per phase instead of the 139A expected. For inherently low power factor equipment, the utility company has to generate much more current than is theoretically required. This excess current flows through generators, cables, and transformers in the same manner as the useful current. If steps are

not taken to improve the power factor of the load, all the equipment from the power station to the installation sub-circuit wiring, has to be larger than necessary. This results in increased capital expenditure and higher transmission and distribution losses throughout the whole network.

To discourage these inefficiencies the electricity companies charge for this wasted power. These charges appear on electricity bills as "reactive power charges", "KVA maximum demand" or "KVA availability charges". For instance known information taken from billing about electrical system:

KVA = 1000, KW = 800, KVAR = 600, PF = .80

Typical Utility Billing Structure Examples:

- I) **90% Billing Structure** - Where demand billed is based on 90% of the KVA or 100% of the KW - Whichever is greater. Because the facility has a power factor of 0.80 they will pay demand rates on 90% of the KVA $1000 \times .90 = 900$ KVA because it is the larger number ($900 \text{ KVA} > 800 \text{ KW}$). Thus the facility is paying a penalty on 100 KVA of unproductive power. Correcting the facility's Power Factor to 90% + will eliminate this penalty cost.
- II) **100% KVA + 100% KW Billing Structure** - Where one rate is applied to 100% of the KVA and another rate is applied to 100% of the KW. Both are then added together to determine the total demand charged on the bill. If we correct the power factor to unity ($\text{KVA} = \text{KW}$ or $800 \text{ KVA} = 800 \text{ KW}$) we can recover costs paid on 200 KVA at *KVA rates. Assuming an equal rate is being paid for KVA and KW

Rather than pay demand costs on $1000 \text{ KVA} + 800 \text{ KW} = 1800$ if the Power Factor = Unity we will pay demand costs on $800 \text{ KVA} + 800 \text{ KW} = 1600$. Savings = $1800 - 1600 = 200$. (More examples are provided later in this paper).

*Note: Generally the cost per KVA is greater than the cost for KW. Thus the savings would be greater by correcting the power factor to unity.

The reactive power charges levied as penalties in the billing should always be regulated. The excess reactive currents and associated charges can be removed by a well-established technology called "Power factor correction". Simply put, this technology offsets the inductive reactive currents by introducing equal and opposite capacitive reactive currents. Typically this can reduce electricity bills by 5-8%, with a payback period of 12 to 18 months. In addition, the consumer shall gain from improved supply availability, improve voltage and reduced power losses.

To improve the power factor, equipment drawing KVAR of approximately the same magnitude as the load KVAR, but in phase opposition 'Leading' is connected in parallel with the load. The resultant KVA is now smaller and the new power factor, cosine ϕ_2 is increased. Thus any value of cosine ϕ_2 can be obtained by controlling the magnitude of the leading KVAR added.

It is never economic to attempt to improve the power factor to unity, since the nearer the approach to unity the more KVAR that must be installed for a given improvement.

Disadvantages of low power factor

Many engineers are oblivious to the effects of low power factor. They view it only as a direct charge on their electrical bill, and only when stated as such. Low power factor is a direct cost to the utility company and must be paid for.

Direct costs of low power factor

Power factor may be billed as one of or combination of, the following:

- 1) A penalty for power factor below and a credit for power factor above a predetermined value,
- 2) An increasing penalty for decreasing power factor,
- 3) A charge on monthly KVAR Hours,
- 4) KVA demand: A straight charge is made for the maximum value of KVA used during the month. Included in this charge is a charge for KVAR since KVAR increase the amount of KVA.

Indirect costs of low power factor

Loss in efficiency of the equipment: When an installation operates with a low power factor, the amount of useful power available inside the installation at the distribution transformers is considerably reduced due to the amount of reactive energy that the transformers have to carry. The figure below indicates the available actual power of distribution equipment designed to supply 1000 KW.

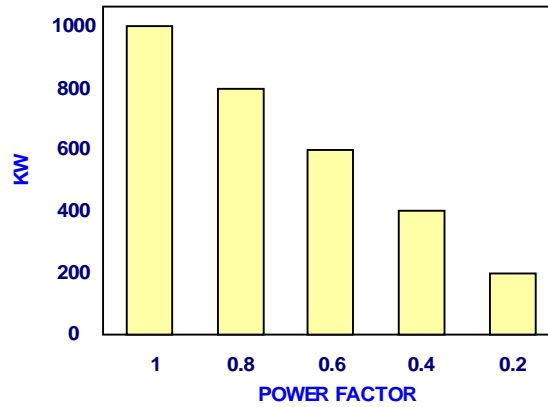

Loss in distribution capacity

The figure below graphically displays the variation of the I^2R losses in feeders and branches. Losses are expressed in percent as a function of power factor.

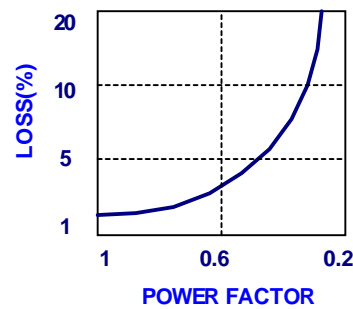

Larger Investment

In case of expansion, a larger investment is required in the equipment needed to increase distribution capability of the installation, such as oversized transformers and switchgears.

Transformers

For an installation which requires 800KW, the transformer should be approximately:

800KVA for power factor = 100%

1000 KVA for power factor = 80%

1600 KVA for power factor = 50%

Large size conductors

The figure below shows a variation of a cross section of a conductor as a function of the power factor for a given useful power. This illustrates that when the power factor of an installation is low, the surcharge on the electricity bill is only part of the problem.

For instance, in an installation where no correction has been made and which has a power factor of 70%, the cross-section of the conductor must be twice as large as it would be if the power factor were 100%.

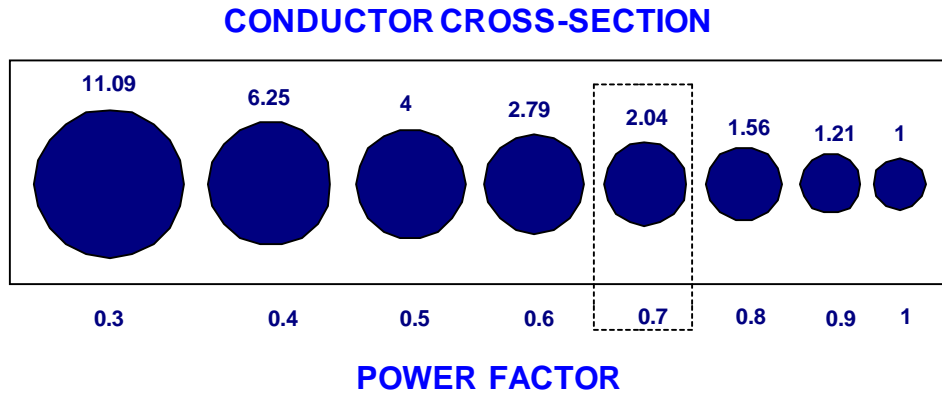

Practically speaking, when an installation uses its rated power capacity, the distribution cables within the installation are rapidly loaded to their full carrying capacity if the power factor decreases. Most often, as the need for energy in an installation expands, the first reaction is to double the distribution system although it would be less expensive to perform a correction of power factor on each load or group of loads.

Benefits of Power Factor Correction

Benefit 1 - Reduce Utility Power Bills

In areas where a KVA demand clause or some other form of low power factor penalty is incorporated in the electric utility's power rate structure, removing system KVAR improves the power factor, reduce power bills by reducing the KVA. Most utility bills are influenced by KVAR usage.

Benefit 2 – Increase System Capacity

The power factor improvement releases system capacity and permits additional loads (motors, lighting, etc.) to be added without overloading the system. In a typical system with a 0.80 PF, only 800 KW of productive power is available out of 1000 KVA installed. By correcting the system to unity (1.0 PF), the KW = KVA. Now the corrected system will support 1000 KW, versus the 800 KW at the .80 PF uncorrected condition; an increase of 200 KW of productive power. This is achieved by adding capacitors which furnish the necessary magnetizing current for induction motors and transformers. Capacitors reduce the current drawn from the power supply; less current means lesser load on transformers and feeder

circuits. Power factor correction through devices such as capacitors can avoid an investment in more expensive transformers, switchgear and cable, otherwise required to serve additional load. The figure below shows the empirical relationship of system capacity vs. power factor. From the figure one can see that improving power factor from .8 to .9 or .8 to .95 shall release approximately 12% or 20% system capacity respectively.

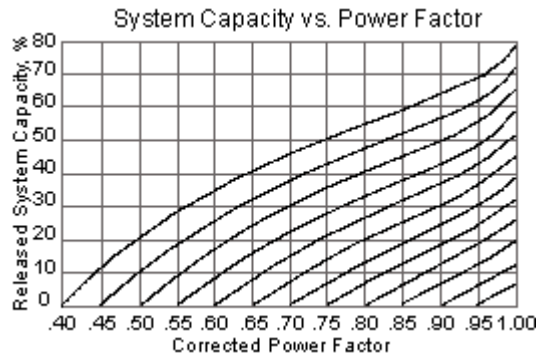

Benefit 3 - Improve System Operating Characteristics (Gain Voltage)

A good power factor (0.95) provides a "stiffer" voltage, typically a 1-2% voltage rise can be expected when power factor is brought to +\-.95. Excessive voltage drops can make your motors sluggish, and cause them to overheat. Low voltage also interferes with lighting, the proper application of motor controls and electrical and electronic instruments. Motor performance is improved and so is production.

An estimate of voltage rise from the improved power factor with the installation of power capacitors can be made using following equation:

$$\% \text{ of Voltage Rise} = \frac{\text{kVAR of capacitors} \times \% \text{ Impedance of Transformer}}{\text{kVA of Transformer}}$$

Benefit 4 - Improve System Operating Characteristics (Reduce Line Losses)

Improving power factor at the load points shall relieve the system of transmitting reactive current. Less current shall mean lower losses in the distribution system of the facility since losses are proportional to the square of the current (I^2R). Therefore, fewer kilowatt-hours need to be purchased from the utility.

An estimate of reduction of power losses can be made using following equation:

$$\% \text{ Reduction of Power Losses} = 100 - 100 \left(\frac{\text{Original Power Factor}}{\text{Improved Power Factor}} \right)^2$$

Equipment Creating Poor Power Factor

It is useful to have an idea of the value of the power factor of commonly used electrical equipment. This will give an idea as to the amount of reactive energy that the network will have to carry. Find below is the summary of power factor of commonly used electrical equipment.

Lighting

Incandescent Lamps: The power factor is equal to unity.

Fluorescent Lamps: Usually have a low power factor, for example, 50% power factor would not be unusual. They are sometimes supplied with a compensation device to correct low power factor.

Mercury Vapor Lamps: The power factor of the lamp is low; it can vary between 40% to 60%, but the lamps are often supplied with correction devices.

Distribution Transformer

The power factor varies considerably as a function of the load and the design of the transformer. A completely unloaded transformer would be very inductive and have a very low power factor.

Electrical Motors

Induction Motors: The power factor varies in accordance with the load. Unloaded or lightly loaded motors exhibit a low power factor. The variation can be 30% to 90%.

Synchronous Motors: Very good power factor when the excitation is properly adjusted.

Synchronous motors can be over excited to exhibit a leading power factor and can be used to compensate a low power system.

Industrial Heating

With resistance, as in ovens or dryers, the power factor is often closed to 100%.

Welding

Electric arc welders generally have a low power factor, around 60%.

Other types of machinery or equipment those are likely to have a low power factor include:

Typical Un-improved Power Factor by Equipment

Equipment	Power Factor
Air Compressor & Pumps (external Motors)	75-80
Hermetic Motors (compressors)	50-80
Arc Welding	35-60
Resistance Welding	40-60
Machining	40-65
Arc Furnaces	75-90
Induction Furnaces (60Hz)	100
Standard Stamping	60-70
High Speed Stamping	45-60
Spraying	60-65

What causes low power factor?

From the above list, we can see that a low power factor can be a result of the design of the equipment, as in the case of welders, or it can be result from the operating conditions under which the equipment is used, as in lightly loaded induction motors which are probably the worst offenders.

Equipment Design

In an old installation, one is limited by the inefficiency of the existing system. However, given the opportunity to expand and purchase new equipment, one should consider some of the energy efficient electric motors that are available today.

Operating Conditions

Load: The power factor of an electrical motor reaches its maximum value under full load. The power factor decreases rapidly when the load decreases. The figure below symbolically illustrates the effect of the load on the power factor of a motor.

Motor Load Factor	Power Factor
Unloaded	17%
1/4 Loaded	55%
1/2 Loaded	73%
3/4 Loaded	80%
Fully Loaded	84%
Overloaded (25%)	86%

Line voltage: Increasing the line voltage on motors and transformers above the rated voltage will increase the consumption of reactive energy. The result will be reduction of power factor. For example, an increase of 10% on the rated voltage can result in 20% reduction of the power factor.

Measurement of Power Factor

The measurement of power factor is the first step in planning any correction. Since each load has its own power factor, the measurements should start with each individual machine and move upward to each distribution panel and finish at the feeder and than to transformer as shown in the figure.

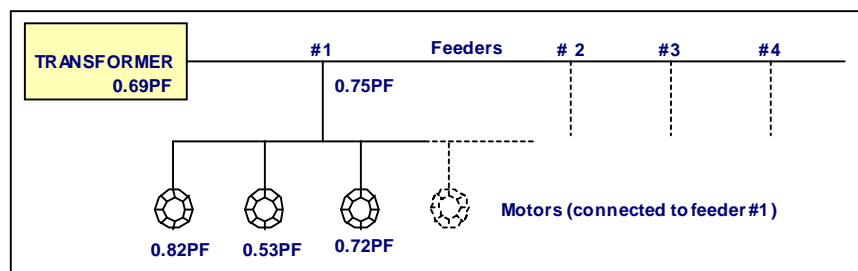

Measuring power factor is a costly procedure when it is required to shut the load down and connect in a metering system to measure the current, voltage and power. So as to avoid the costly shutdown and time-consuming measurement, it is preferable to use a clamp on power factor meter.

To connect the meter, the voltage leads are first connected to the meter and then clipped to the phases supplying the load. The clamp on current transformer is then clamped on to the phase supplying the load. To select the appropriate clamp on CT, a conventional clamp tester

is used to measure the load current. The voltage is also measured. Now using the clamp on, power factor meter with appropriate CT, the power factor reading is noted.

The necessary data for desired power factor correction is current, line voltage and existing power factor. Now that the survey has been completed and it has been determined that power factor is a problem, the final step is to improve it. There are several approaches:

Power Factor Correction

Power factor correction can be made in two ways:

- 1) Reduce the amount of reactive energy
 - Eliminate unloaded motors and transformers
 - Avoid supplying equipment with voltage in excess of the rated voltage
- 2) Compensate artificially for the consumption of reactive energy with power factor capacitors. In practice, two type of equipment are available for power factor correction:
 - a. Rotary Equipment: Phase advancers, synchronous motors and synchronous condensers. Where auto-synchronous motors are employed the power factor correction may be a secondary function.
 - b. Capacitors: Power factor correction is achieved by the addition of capacitors in parallel with the connected motor circuits and can be applied at the starter, or applied at the switchboard or distribution panel.

Capacitors connected at each starter and controlled by each starter is known as "Static Power Factor Correction" while capacitors connected at a distribution board and controlled independently from the individual starters is known as "Bulk Correction".

When installing equipment, the following points are normally considered:

- 3) Reliability of the equipment to be installed
- 4) Probable life of such equipment
- 5) Capital cost
- 6) Maintenance cost
- 7) Running cost
- 8) Space required and ease of installation

Generally the cost of rotating machinery, both synchronous and phase advancing, makes its use uneconomical, except where one is using rotating plant for a dual function – drive and

power factor correction. In addition the wear and tear inherent in all rotating machines involves additional expense for upkeep and maintenance.

Capacitors have none of these disadvantages. Compared with other forms of correction, the initial cost is very low, upkeep costs are minimal and they can be used with the same high efficiency on all sizes of installation. They are compact, reliable, highly efficient & convenient to install and lend themselves to individual, group or automatic method of correction. These facts indicate that generally speaking, power factor correction by means of capacitors is the most satisfactory and economical methods.

The static capacitor owing to its low losses, simplicity and high efficiency is now used almost universally for power factor correction.

What is a Capacitor?

Simply put, a capacitor is an electric device that can store electric charge for later release. Generally, capacitors are used in one of the three ways: to store and release energy, to discriminate between DC (direct current) and AC (alternating current) frequencies, and to discriminate between higher and lower AC frequencies.

A simple capacitor consists of two metal plates that are held parallel to each other with a small space between them. An insulating material called dielectric occupies the space. This insulating material can be made of many materials including oil, paper, glass, ceramics, and mica, plastic, or even air. Capacitance is a measure of the energy that a capacitor is capable of storing. The capacitance of a device is directly proportional to the surface areas of the plates and inversely proportional to the plates' separation.

How Capacitors Work

Induction motors, transformers and many other electrical loads require magnetizing current (KVAR) as well as actual power (KW). By representing these components of apparent power (KVA) as the sides of a right triangle, we can determine the apparent power from the right triangle rule: $KVA^2 = KW^2 + KVAR^2$. To reduce the KVA required for any given load, you must shorten the line that represents the KVAR. This is precisely what capacitors do.

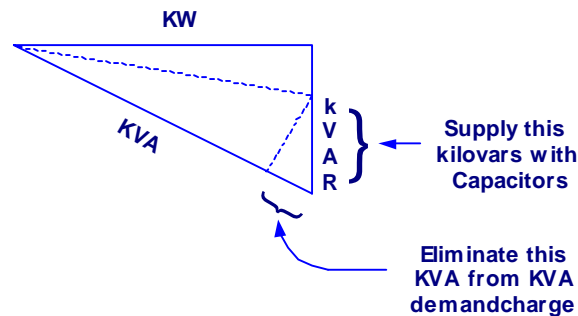

The capacitor performs the function of an energy storage device. By supplying KVAR right at the load, the capacitors relieve the utility of the burden of carrying the extra KVAR. This makes the utility transmission/distribution system more efficient, reducing cost for the utility and their customers.

The figure below shows an induction motor operating under partially loaded conditions without power factor correction. Here the feeder line must supply both magnetizing (reactive) and useful currents.

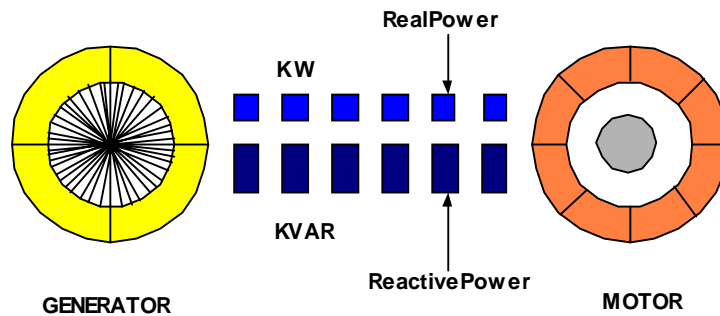

The figure below shows the results of installing a capacitor near the same motor to supply the magnetizing current required to operate it. The total current requirement has been reduced to the value of the useful current only, thus either reducing power cost or permitting the use of more electrical equipment on the same circuit.

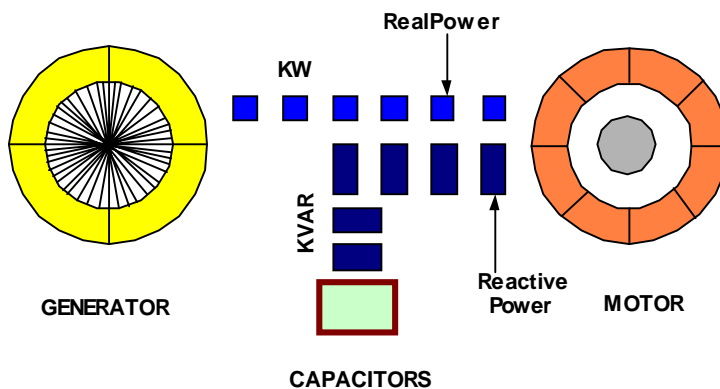

In the illustration above, addition of the capacitor has improved line power factor and subtracted the non-working current from the lines. Rather than transfer energy back and forth between load and generator, the reactive energy to supply the magnetizing current is now stored in a capacitor at the load, thus reducing the distribution requirements for excessive current. This reactive current supplied by the capacitor rather than the utility.

Correction Methods

Static or fixed Power Factor correction

Compensation on the load side of the AC motor starter (motor switched or "at the load"). Fixed capacitors provide a constant amount of reactive power to an electrical system. Primarily, fixed capacitors are applied to individual motor loads, but they can also be applied to the main power bus with proper treatment. Fixed capacitors are suitable for indoor or outdoor use. Fixed capacitors are available in low voltages (832 volt and below), from .5 KVAR up to 400 KVAR (If more than 400 KVAR is required, smaller units are paralleled together).

Central or Bulk Power Factor correction

Central power factor compensation is applied for electrical systems with fluctuating loads. The central power factor correction is usually installed at the main power distribution. The capacitors are controlled by a microprocessor-based relay, which continuously monitors the power factor of the total current supplied to the distribution board. The relay then connects or disconnects capacitors to supply capacitance as needed in a fashion to maintain a power factor better than a preset limit (typically 0.95). Ideally, the power factor should be as close to unity as possible.

When harmonic distortion is a concern, systems are built based on the principles explained under 'Harmonic Distortion and Power Factor Correction' later in this paper.

Determining Capacitor Requirements

The total KVAR rating of capacitors required to improve the power factor to any desired value can be calculated by using the tables published by leading power factor capacitor manufacturers.

Calculation Table for Capacitor Selection

Power factor Cos θ_2 after improvement														
	1.0	0.99	0.98	0.97	0.96	0.95	0.94	0.93	0.92	0.91	0.90	0.85	0.80	
Power factor Cos θ_1 before improvement	0.5	1.73	1.59	1.53	1.48	1.44	1.40	1.37	1.34	1.30	1.28	1.25	1.11	0.98
	0.52	1.64	1.50	1.44	1.39	1.35	1.32	1.28	1.25	1.22	1.19	1.16	1.02	0.89
	0.55	1.52	1.38	1.32	1.27	1.23	1.19	1.16	1.12	1.09	1.06	1.04	0.90	0.77
	0.57	1.44	1.30	1.24	1.19	1.15	1.11	1.08	1.05	1.01	0.99	0.96	0.82	0.69
	0.6	1.33	1.19	1.13	1.08	1.04	1.01	0.97	0.94	0.91	0.88	0.85	0.71	0.58
	0.62	1.27	1.23	1.06	1.01	0.97	0.94	0.90	0.87	0.84	0.81	0.78	0.65	0.52
	0.65	1.17	1.03	0.97	0.92	0.88	0.84	0.81	0.77	0.74	0.71	0.69	0.55	0.42
	0.67	1.11	0.97	0.91	0.86	0.82	0.78	0.75	0.71	0.68	0.65	0.62	0.49	0.36
	0.7	1.02	0.88	0.81	0.77	0.73	0.69	0.66	0.62	0.59	0.56	0.54	0.40	0.27
	0.72	0.96	0.82	0.75	0.71	0.67	0.63	0.60	0.57	0.53	0.51	0.48	0.34	0.21
	0.75	0.88	0.74	0.67	0.63	0.58	0.55	0.52	0.49	0.45	0.43	0.40	0.26	0.13
	0.77	0.83	0.69	0.62	0.58	0.54	0.50	0.47	0.43	0.40	0.37	0.35	0.21	0.08
	0.8	0.75	0.61	0.54	0.50	0.46	0.42	0.39	0.35	0.32	0.29	0.27	0.13	
	0.82	0.70	0.56	0.49	0.45	0.41	0.37	0.34	0.30	0.27	0.24	0.21	0.08	
	0.85	0.62	0.48	0.42	0.37	0.33	0.29	0.26	0.22	0.19	0.16	0.14		
	0.87	0.57	0.42	0.36	0.32	0.28	0.24	0.20	0.17	0.14	0.11	0.08		
	0.90	0.48	0.34	0.28	0.23	0.19	0.16	0.12	0.09	0.06	0.02			
	0.91	0.45	0.31	0.25	0.21	0.16	0.13	0.09	0.06	0.02				
	0.92	0.43	0.28	0.22	0.18	0.13	0.10	0.06	0.03					
	0.93	0.40	0.25	0.19	0.15	0.10	0.07	0.03						
0.94	0.36	0.22	0.16	0.11	0.07	0.04								
0.95	0.33	0.18	0.12	0.08	0.04									
0.96	0.29	0.15	0.09	0.04										
0.97	0.25	0.11	0.05											
0.98	0.20	0.06												
0.99	0.14													

To properly select the amount of KVAR required to correct the lagging power factor of a 3-phase motor you must follow the steps as stated.

Step #1: Determine KW and Existing Power Factor.

Step # 2: Existing Power Factor on Table, move across table to Desired Power Factor. The number represented is your multiplier number.

Step #3: Multiply KW by the multiplier of the Desired Power Factor.

Example-1

Assume factory load: 200 KW

Power factor before improvement: $\cos \theta_1 = 0.80$

Expected power factor: $\cos \theta_2 = 0.95$

Ratio of needed power capacity calculated from the above table is 0.42 thus needed capacity
 $C = 200 \times 0.42 = 84$ KVAR

If KW or present power factor is not known you can calculate from the following formulas (applicable for 3 phase supply) to get the three basic pieces of information required calculating KVAR:

$$PF = \frac{kW}{kVA}$$

$$kVA = \frac{1.73 \times I \times E}{1000}$$

$$kW = \frac{1.73 \times I \times E \times PF}{1000} \quad \text{or} \quad kW = \frac{HP \times .746}{\text{eff.}}$$

Where

I = full load current in amps

E = voltage of motor

PF = Present power factor as a decimal (80% = 0.80)

HP = rated horsepower of motor

eff. = rated efficiency of motor as a decimal (83% = .83)

If desired power factor is not provided, 95% is a good economical power factor for calculation purposes.

Example-2

How many KVAR are needed to correct an existing power factor of 62% to 95% for three phase induction motor operating at 480V and 62A?

Solution

1. Actual power:

$$KW = 480 \times 62 \times 0.62 \times 1.732/1000 = \sim 32 \text{ KW}$$

2. The leading reactive power KVAR necessary to raise the power factor to 95% is found by multiplying 32 KW by the factor found from the correction table for capacitor selection (refer above) , which is 0.937

$$32 \text{ KW} \times 0.937 = 29.98 \text{ KVAR}$$

We use 30 KVAR

Example-3

An energy audit for a facility indicates following measurements at the load side of the transformer; 480V, 1200A and 800 KW operating load.

- i. What is the Power Factor?
- ii. How much Reactive Power (KVAR) is in the system?

Solution

i) To calculate the Power Factor, we must first calculate the KVA in the system.

$$\mathbf{KVA} = \frac{V \times A \times \sqrt{3}}{1000} = \frac{480 \times 1200 \times \sqrt{3}}{1000} = \mathbf{1000kVA}$$

Substitute the KVA into the Power Factor Formula

$$\mathbf{P.F.} = \frac{KW}{kVA} = \frac{800}{1000} = \mathbf{.80 \text{ or } 80\% \text{ P.F.}}$$

ii) To calculate the Reactive Power (KVAR) in the system requires re-arranging the formula $kVA^2 = KW^2 + kVAR^2$ and solving for KVAR.

Example - 4

The measurement at the main distribution board of a manufacturing industry indicates 1000 KVA and 800 KW. Determine the system KVAR and PF of the facility. Determine also the KVAR required for achieving power factor of 0.95 while providing the same productive power of 800 KW?

Solution

Measured KVA = 1000

Measured KW = 800

i) System KVAR and PF of the facility

$$\mathbf{kVAR} = \sqrt{kVA^2 - KW^2} = \sqrt{1000^2 - 800^2} = \mathbf{600kVAR}$$

$$\mathbf{P.F.} = \frac{KW}{kVA} = \frac{800}{1000} = \mathbf{.80 \text{ or } 80\% \text{ P.F.}}$$

ii) System KVAR after power factor correction to .95

System KVA after correction

$$\mathbf{kVA} = \frac{KW}{PF} = \frac{800}{.95} = \mathbf{843}$$

System KVAR after correction

$$\mathbf{kVAR} = \sqrt{kVA^2 - KW^2} = \sqrt{843^2 - 800^2} = \mathbf{265kVAR}$$

iii) Power capacitor KVAR rating

Power Capacitor KVAR = KVAR (uncorrected) – KVAR (corrected)

$$= 600 - 265 = 335 \text{ KVAR}$$

We can use the multiplier table for capacitor selection (refer above) straight away when the KW load, uncorrected power factor and the desired power factor are known as shown in examples above.

Example - 5:

Billing based on KW Demand Charges

An industrial plant has a demand of 1000 KW and operates at 80% power factor. The utility company supplying power to this unit requires minimum power factor of 85% and levies a KW demand charge of \$8.00 in the electricity bill. Determine the savings possible by improving the power factor to a minimum required target of 0.85 along with the payback period of putting any investment on power factor correction.

Solution

i) The monthly KW billing is determined by the ratio of target power factor to the existing power factor times KW demand.

KW billing on power factor of 0.80

The amount of monthly KW billing: $1000KW \times 0.85 \text{ target PF} / 0.80 \text{ existing PF} = 1062 \text{ KW}$

Total demand charge @ \$ 8.00 = $1062KW \times \$ 8.00 = \8496

ii) KVAR required to increase power factor from 0.8 to 0.85

The multiplying factor = 0.13 (from the capacitor estimation table above)

Therefore KVAR required = $0.13 \times 1000 = 130 \text{ KVAR}$

iii) Capacitor Investment

Cost of 130 KVAR of capacitors (on a 480 volt system, installed capacitor cost is approx \$15/KVAR)

$$130\text{KVAR} \times \$ 15.00 = \$ 1950$$

iv) KW billing on new Power Factor of 0.85

The amount of monthly KW billing: $1000\text{KW} \times 0.85 \text{ target PF} / 0.85 \text{ modified PF} = 1000 \text{ KW}$

Modified demand charge @ \$ 8.00 = $1000 \text{ KW} \times \$ 8.00 = \8000

v) Payback Period

$$\text{Monthly savings on demand charge} = \$8496 - \$8000 = \$496$$

$$\text{Investment on capacitors} = \$ 1950$$

Simple Payback = First cost/ savings = $\$1950 / \$496 = \text{approx } 3.9 \text{ months}$. The savings shall continue thereafter.

Example - 6:

Billing based on KVA Demand Charges

An industrial plant is operating at 400 KW and maximum demand of 520 KVA. The facility has a power contract based KVA demand charges, which shall reduce as the power factor is improved. The demand charges rates have been fixed @ \$3.00 per month per KVA.

Determine the savings possible by improving the power factor along with the payback period of putting any investment on power factor correction.

Solution

The KVA demand can be reduced if the power factor is raised. Often 95% is a good economical power factor when the demand charges are based on KVA charges.

i) The Present Power Factor = $\text{KW/KVA} = 400/520 = 77\%$

ii) Present demand charge = $520 \times \$ 3 = \1560

iii) Assuming that we target the new power factor to 95%. This would reduce the present 520 KVA demand down to 421KVA. Calculation as follows:

$$\text{Reduced KVA} = \text{KW/modified power factor} = 400/0.95 = 421\text{KVA}$$

iv) Modified demand charge = $421 \times \$ 3 = \1263

v) Probable Savings = $\$1560 - \$1263 = \$297$

vi) KVAR required to increase power factor from 0.77 to 0.95

The multiplying factor = 0.5 (from the capacitor estimation table above)

Therefore KVAR required = $0.5 \times 400 = 200$ KVAR

vii) Capacitor Investment

Cost of 200 KVAR of capacitors (on a 480 volt system, installed capacitor cost is approx \$15/KVAR)

$200 \text{ KVAR} \times \$ 15.00 = \$ 3000$

viii) Payback Period

Monthly savings on demand charge = \$297

Investment on capacitors = \$ 3000

Simple Payback = First cost/ savings = $\$ 3000 / \$297 =$ approx 10 months. The savings shall continue thereafter.

In addition, by installing the 200 KVAR of capacitors an additional 20% capacity is immediately available for new motor and lighting loads without installing any new transformers, power lines or distribution equipment. This is important because in critical times the new transformers and power lines may be difficult to obtain, and their costs, in most cases, would exceed the \$3000 spent for capacitors.

Example – 7

Billing Based on KW & KVAR Demand Charges

A hotel complex with majority of HVAC and lighting load has a contract for power factor which includes an energy charge for KWH, a demand charge based on KW and another demand charge based on KVAR. The KVAR charge is \$1.5 per month for each KVAR of demand in excess of 1/3 of the KW demand. The operating electrical characteristics are 1800 KVA, 1350 kW and 1200 KVAR. Determine the possible savings on reducing the KVAR demand charges by addition of power factor correction capacitors along with the simple payback.

Solution:

i) The KVAR demand can be eliminated by the addition of capacitors. KVAR demand in excess of 1/3 of the kW demand can be calculated as:

$$1200 \text{ KVAR} - \frac{1350 \text{ kW}}{3} = 750 \text{ KVAR} \times 1$$

This implies that 750 KVAR supplies, if provided by capacitors can do away with this extra demand charges.

ii) Estimated annual power bill savings

$\$1.50 \text{ demand charge} \times 750 \text{ KVAR} \times 12 \text{ months} = \$13,500 \text{ savings per annum}$

iii) Estimated cost of 750 KVAR capacitors

Probable cost of 480 volt, 60 Hz capacitors shall be \$ 15 per KVAR. Therefore total investment for 750 KVAR capacitors shall be

$750 \text{ KVAR} \times \$15 = \$11,250$

iv) Simple Payback Period

$\$13,500 \text{ annual savings vs. } \$11,250 \text{ capacitor investment}$

Capacitors will pay for themselves in 10 months, and continue to produce savings thereafter.

Example - 8:

Increased System Capacity

A facility electrical system is operating at following characteristics: KVA = 1000, KW = 800, KVAR = 600, PF = 0.80 Determine how much spare capacity can be released by improving power factor to 0.95.

Solution

The uncorrected system can only support 800 KW of Productive Power at a PF of 0.80

The figure below shows the empirical relationship of system capacity vs. power factor. From the figure one can see that improving power factor from 0.8 to 0.95 shall release approximately 20% system capacity.

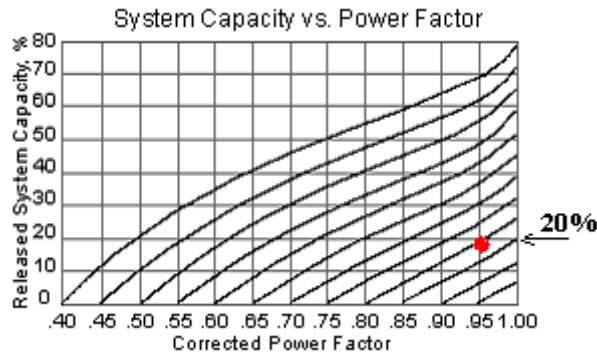

The corrected system is now capable of supporting 960 KW of productive power.

The system capacity has been increased by 160 KW.

Example - 9:

Lower Losses

Assume facility system wide losses = 5% with a current power factor of 0.80. Estimate the reduction in losses when the power factor correction is made at the load points to unity.

Solution:

Improving power factor at the load points shall relieve the system of transmitting reactive current. Less current shall mean lower losses in the distribution system of the facility since losses are proportional to the square of the current (I^2R). Therefore, fewer kilowatt-hours need to be purchased from the utility.

An estimate of reduction of power losses can be made using following equation:

$$\% \text{ Reduction of Power Losses} = 100 - 100 \left(\frac{\text{Original Power Factor}}{\text{Improved Power Factor}} \right)^2$$

$$\begin{aligned} \text{Or } & 100 - 100(.80 / 1.0)^2 \\ & = 100 - 100(.64) = 36\% \end{aligned}$$

The original facility system losses of 5% are reduced by $5 \times 36 / 100 = 1.8\%$

As a result the monthly KWH billing is reduced by 1.8%, an additional savings.

Typical Locations for Power Capacitors (Where/ What Type to Install)

The successful operation of a power factor correction depends largely on the correct positioning of the capacitors in the network; the importance of studying all relevant factors is emphasized. The relevant factors are: tariff in force; metering point; details of light, average, and full load KVA, KW and power factor; position of motors, welding equipment, transformers or other equipment causing bad power factor; and supply system problems such as harmonics. The siting of the capacitors, does to some extent, depends on whether each piece of equipment e.g. a motor, or a transformer, is being individually corrected or the installation as a whole or part is being corrected as a block (generally known as bulk or group connection). In the first case the capacitor and the load (motor, transformer etc.) are as close together as possible; in the second case the capacitor is located at some convenient point in the system, such as a substation.

Before power capacitors can be placed, the physical location of the utility meter should be determined since all power capacitors must be installed “downstream” of the meter.

There are three basic locations for Power Capacitors:

Option #1: Individual capacitor installation at the level of each machine

- Load side of the AC motor, commonly referred to as “at the load” or “motor switched”

When the capacitors are installed directly at the induction motor terminals (on the secondary of the overload relay), the capacitors are turned on and off with the motors, eliminating the need for separate switching devices or over current protection. The capacitor/s is only energized when then motor is running.

Capacitors installed near the loads in a plant provide spot delivery of magnetizing current (KVAR) just at the load, which eliminates unnecessary reactive current in the feeder lines thereby reducing the line losses, minimizing voltage drops and maximizing system capacity. This is one of the most economical and efficient ways of supplying these kilovars, which relieves both you and your utility of the cost of carrying this extra kilovar load.

The drawback is that large number of capacitors may be needed for individual motor correction, increasing the installation costs (\$ per KVAR compensation). Also overload relay settings need to be changed to account for lower motor current draw. If the capacitors are installed between the contractor and the overload relay, the overload relay can be set for nameplate full load current of motor.

Option #2: Group or bank installation

- Small motors operating from a common starter
- Load side of the utility transformer on the distribution bus
- Bank installation at Feeders, Sub-stations, or Transformers

Installing capacitors between the upstream circuit breaker & the contactor or at the main distribution bus ensures lower installation cost since you install fewer banks in large KVAR blocks. The drawback is that since reactive current must be carried a greater distance, there are higher line losses and larger voltage drops. Another drawback is that overcorrection may occur under lightly loaded conditions. A separate disconnect switch and over current protection is required. It is recommended to consider automatic switched banks with such an installation.

Option #3: Mixed installation, at both the individual and group level

Installations not operating continuously and which may be supplied at high voltage but with low voltage loads should employ low voltage capacitors for power factor improvement. Low voltage switch gear is much cheaper than high voltage switch gear and obviously is available with much lower ratings which enable relatively small capacitor steps (100 KVAR and below) to be employed for automatically controlled capacitors. This ensures flexibility of operation without excessive switchgear costs. The advantages and drawbacks of option #3 shall be same as discussed under option #1 and option #2.

In providing the power factor correction it should be remembered that distribution boards and circuits can carry a greater useful load if the capacitors are installed as near as possible to the source of low power factor. For this reason either bulk or individual correction, rather than correction at the intake point, can almost invariably be justified.

In an installation where the low voltage load is supplied from several distribution substations, local automatic control at each substation is generally much cheaper as well as operationally superior to an elaborate method of overall control operated from the point of incoming supply.

After careful consideration of the advantages and disadvantages of the various installation options, care must be taken in sizing and placing power factor correction capacitors. Leading power factor, greater than 100%, must be avoided. The capacitors should only be on line when the load requires KVAR and disconnected when the load is reduced.

How to Switch Capacitors Separately

When a group of motors are so operated that some run while others are idle, single capacitor equipment (containing a number of individual capacitor units) can be connected to the bus to economically supply kilovars to the group. Capacitor equipments of this type need a separate switching device. The interrupting rating of the switching device should be at least as great as the short-circuit current available on the system on which it is applied. The switching device should be sized to exceed the capacitor nominal current as follows:

- Magnetic breakers: 135%
- Fusible switches: 165%
- Molded case breakers: 150%

For small capacitors, a separate wall-mounted switch or air circuit breaker of the enclosed type can be used. For large capacitors, the breaker or switch can be housed with the capacitors. When connected through metal-clad switchgear, capacitors should be treated as any other load and the breaker added to the existing switchgear.

If a large number of switching operations are expected, a solenoid-operated contactor may be used in place of a circuit breaker. The contactor offers a much longer expected life when switching normal load current. However, it does not provide short-circuit protection, so fuses must be added for this purpose where contactors are used.

Automatic Switching of Capacitors

Automatic switching of capacitors is an ideal method of obtaining the full electrical and financial benefits from a capacitor installation. Automatic power factor correction is a microprocessor-controlled system designed to continuously regulate the power factor to the

specified levels by adjusting the amount of KVAR in relation to the variations in load. The system consists of a capacitor banks subdivided into a number of equal steps, each step being controlled by a multi-step relay and air break contactors connected to the main bus bars. Each capacitor bank incorporates multiple single-phase cells that are wired in a delta connection for three-phase operation.

The target value of the power factor is adjustable. The operation is controlled by load current (CT) according to the power factor, which is determined by the demand to control on/off the capacitors. During initial switch-on, the unit self checks the current and voltage connections and, if incorrect, displays a fault signal. The value of each stage can be programmed in manually or if a 'self current' CT is fitted, the unit steps through the stages and memorizes the capacitive reactive power of each stage (learning mode). The unit can then select which step to switch to achieve the target power factor with the least switching operations.

Where contactor switching is used, a delay is programmed in to allow previously energized capacitors to discharge before being reconnected. Where thyristor switching is employed, this delay is not necessary as the switching takes place at zero volts.

The auto-control of the capacitor banks ensures that over-correction will not occur.

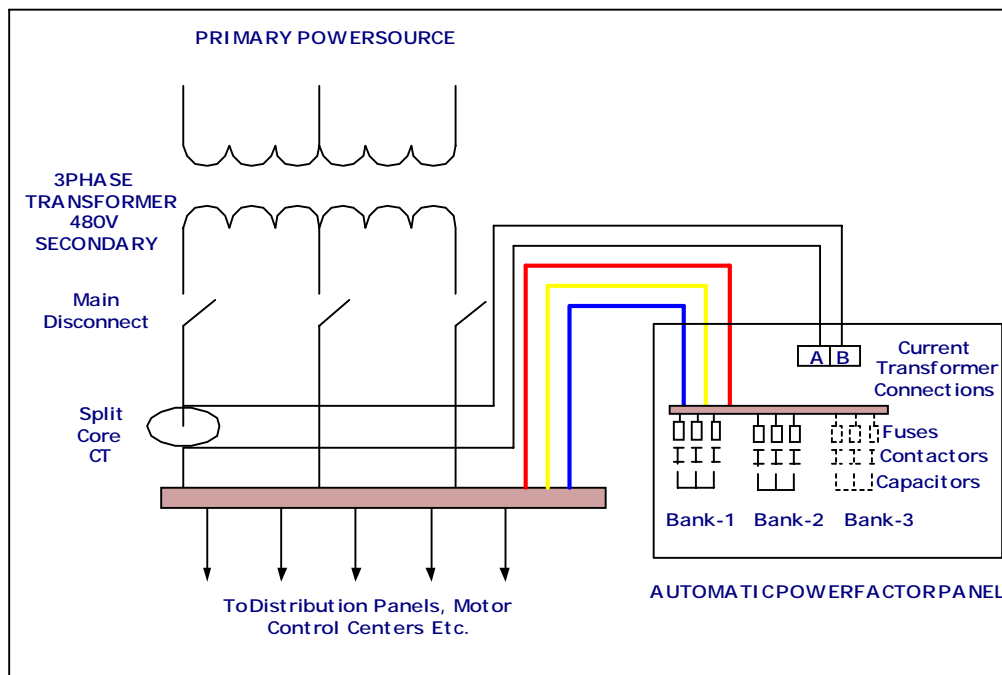

The number of stages installed is usually a compromise between the technical requirements and cost. Studies indicate that the resulting benefits, economies and convenience of automatic system far outweighing the initial cost.

The power factor controller can be programmed with many additional features. To protect the capacitors, the regulators are equipped with an automatic shutdown facility in the event of excess voltage or excess harmonics. A contact for a remote alarm may be included with programmable delay time. The regulators should have digital display of PF, current, volts, active power, reactive power, network harmonics and KVAR required to achieve target power factor.

Size of capacitor bank

Capacitors are rated in kilovars or KVAR. Common sizes are 1, 2, 3, 4, 5, 6, 7, 8, 10/12/15/20 and 25 KVAR at 415 or 440V alternating current, 3 phase, 50 Hz. Usually more than one capacitor is required give the desired degree of power factor correction. Groups of capacitors are factory assembled in various configurations. Standard capacitor ratings are designed for 50 or 60Hz operation. When operated at less than nameplate frequency of 50 or 60Hz, the actual KVAR attained will be less than rated KVAR. If the operating voltage is less than the rated voltage, a reduction in the nameplate KVAR will be realized. The following equation defines the relation:

$$\text{KVAR} = 2\pi f C E^2 \times 10^{-3}$$

$$C = \frac{\text{KVAR}}{2\pi f E^2 \times 10^{-3}}$$

$$\pi = 3.1416$$

$$f = \text{Hz}$$

$$C = \mu\text{F}$$

$$E = \text{KV}$$

Capacitor Required for Correction of Individual Motors

For correction to Power Factor of 0.95 of 415 Volts, 3 phase 4 pole motors with average characteristics can be referred from the following tables. The table-1 below is a generic table to be applied as a rule of thumb.

Table - 1

MOTOR SIZE (KW)	CORRECTION (KVAR)	CAPACITOR FUSING (Amps)
3.0	1.5	4
4.0	2.0	4
5.5	2.5	6
7.5	3.0	6
11	5.0	10
15	6.25	16
18.5	8.0	16
22	10.0	20
30	12.5	25
37	15.0	32
45	15.0	32
55	20.0	40
75	20.0	40
90	25.0	50
110	25.0	50
132	30.0	63
150	35.0	80
185	40.0	80
220	45.0	100
250	50.0	100

**Suggested Capacitor Ratings for T-Frame NEMA Class B
Motors
Table - 2**

Induction Motor Horsepower Rating	3600 RPM		1800 RPM		1200 RPM		900 RPM		720 RPM		600 RPM	
	Capacitor kVAR	Current Reduction %	Capacitor kVAR	Current Reduction %	Capacitor kVAR	Current Reduction %	Capacitor kVAR	Current Reduction %	Capacitor kVAR	Current Reduction %	Capacitor kVAR	Current Reduction %
2	1	14	1	24	1.5	30	2	42	2	40	3	50
3	1.5	14	1.5	23	2	28	3	38	3	40	4	49
5	2	14	2.5	22	3	26	4	31	4	40	5	49
7.5	2.5	14	3	20	4	21	5	28	5	38	6	45
10	4	14	4	18	5	21	6	27	7.5	36	8	38
15	5	12	5	18	6	20	7.5	24	8	32	10	34
20	6	12	6	17	7.5	19	9	23	10	29	12.5	30
25	7.5	12	7.5	17	8	19	10	23	12.5	25	17.5	30
30	8	11	8	16	10	19	15	22	15	24	20	30
40	12.5	12	15	16	15	19	17.5	21	20	24	25	30
50	15	12	17.5	15	20	19	22.5	21	22.5	24	30	30
60	17.5	12	20	15	22.5	17	25	20	30	22	35	28
75	20	12	25	14	25	15	30	17	35	21	40	19
100	22.5	11	30	14	30	12	35	16	40	15	45	17
125	25	10	35	12	5	12	40	14	45	15	50	17
150	30	10	40	12	40	12	50	14	50	13	60	17
200	35	10	50	11	50	11	70	14	70	13	90	17
250	40	11	60	10	60	10	80	13	90	13	100	17
300	45	11	70	10	75	12	100	14	100	13	120	17
350	50	12	75	8	90	12	120	13	120	13	135	15
400	75	10	80	8	100	12	130	13	140	13	150	15
450	80	8	90	8	120	10	140	12	160	14	160	15
500	100	8	120	9	150	12	160	12	180	13	180	15

**Suggested Capacitor Ratings for High-Efficiency motors
Table - 3**

Induction Motor Horsepower Rating	Number of Poles and nominal motor speed in RPM											
	2 - 3600 RPM		4 - 1800 RPM		6 - 1200 RPM		8 - 900 RPM		10 - 720 RPM		12 - 600 RPM	
	Capacitor kVAR	Current Reduction %	Capacitor kVAR	Current Reduction %	Capacitor kVAR	Current Reduction %	Capacitor kVAR	Current Reduction %	Capacitor kVAR	Current Reduction %	Capacitor kVAR	Current Reduction %
3	1.5	14	1.5	15	1.5	20	2	27	2.5	35	3	41
5	2	12	2	13	2	17	3	25	4	32	4	37
7.5	2.5	11	2.5	12	3	15	4	22	5	30	6	34
10	3	10	3	11	3	14	5	21	6	27	7.5	31
15	4	9	4	10	5	13	6	18	8	23	9	27
20	5	9	5	10	6	12	7.5	16	9	21	12.5	25
25	6	9	6	10	7.5	11	9	15	10	20	15	23
30	7	8	7	9	9	11	10	14	12.5	18	17.5	22
40	9	8	9	9	10	10	12.5	13	15	16	20	20
50	12.5	8	10	9	12.5	10	13	12	20	15	25	19
60	15	8	15	8	15	10	17.5	11	22.5	15	27.5	19
75	17.5	8	17.5	8	17.5	10	20	10	25	14	35	18
100	22.5	8	20	8	20	9	27.5	10	35	13	40	17
125	27.5	8	25	8	30	9	30	10	40	13	50	16
150	30	8	30	8	35	9	37.5	10	50	12	50	15
200	4	8	37.5	8	40	8	50	10	60	12	60	14
250	50	8	45	7	50	8	60	9	70	11	75	13
300	60	8	50	7	60	8	60	9	80	11	90	12
350	60	8	60	7	75	8	75	9	90	10	95	11
400	75	8	60	6	75	8	85	9	95	10	100	11
450	75	8	75	6	80	8	90	9	100	9	110	11
500	75	8	75	6	85	8	100	9	100	9	120	10

Note: For use with three-phase, 600Hz Design B motors (NEMA MG 1-1993) to raise full-load power factor to approximately 95%.

Important Considerations for Static Power Factor Correction

As a large proportion of the inductive or lagging current on the supply is due to the magnetizing current of induction motors, it is easy to correct each individual motor by connecting the correction capacitors to the motor starters. *With static correction, it is important that the capacitive current is less than the inductive magnetizing current of the induction motor.* In many installations employing static power factor correction, the correction capacitors are connected directly in parallel with the motor windings. When the motor is 'Off Line', the capacitors are also 'Off Line'. When the motor is connected to the supply, the capacitors are also connected providing correction at all times that the motor is connected to the supply. This removes the requirement for any expensive power factor monitoring and control equipment. In this situation, the capacitors remain connected to the motor terminals as the motor slows down.

Never overcorrect the motor when static correction is applied....

An induction motor, while connected to the supply, is driven by a rotating magnetic field in the stator, which induces, current into the rotor. When the motor is disconnected from the supply, there is for a period of time, a magnetic field associated with the rotor. As the motor decelerates, it generates voltage out its terminals at a frequency, which is related to its speed. The capacitors connected across the motor terminals, form a resonant circuit with the motor inductance. If the motor is critically corrected, (corrected to a power factor of 1.0) the inductive reactance equals the capacitive reactance at the line frequency and therefore the resonant frequency is equal to the line frequency. If the motor is over corrected, the resonant frequency will be below the line frequency. If the frequency of the voltage generated by the decelerating motor passes through the resonant frequency of the corrected motor, there will be high currents and voltages around the motor/capacitor circuit. This can result in severe damage to the capacitors and motor. It is imperative that motors are never over corrected or critically corrected when static correction is employed. Ideally, static power factor correction should provide capacitive current equal to 80% of the magnetizing current, which is essentially the open shaft current of the motor.

The magnetizing current for induction motors can vary considerably...

Typically, magnetizing currents for large two pole machines can be as low as 20% of the rated current of the motor while smaller low speed motors can have a magnetizing current as high as 60% of the rated full load current of the motor. It is not practical to use a "Standard table" for the correction of induction motors giving optimum correction on all motors. Tables result in under correction on most motors but can result in over correction in some cases. Where the open shaft current cannot be measured, and the magnetizing current is not quoted, an approximate level for the maximum correction that can be applied can be

calculated from the half load characteristics of the motor. It is dangerous to base correction on the full load characteristics of the motor as in some cases, motors can exhibit a high leakage reactance and correction to 0.95 at full load will result in overcorrection under no load, or disconnected conditions.

Providing Static Correction...

Static correction is commonly applied by using one contactor to control both the motor and the capacitors. It is better practice to use two contactors, one for the motor and one for the capacitors. Where one contactor is employed, it should be up sized for the capacitive load. The use of a second contactor eliminates the problems of resonance between the motor and the capacitors.

Where not to use Static Power Factor Correction...

- a. **Inverter:** Static Power factor correction must not be used when a variable speed drive or inverter controls the motor.
- b. **Solid State Soft Starter:** Static Power Factor correction capacitors must not be connected to the output of a solid-state soft starter. When a solid-state soft starter is used, the capacitors must be controlled by a separate contactor, and switched in when the soft starter output voltage has reached line voltage. Many soft starters provide a "top of ramp" or "bypass contactor control" which can be used to control the power factor correction capacitors."

Harmonic Distortion and Power Factor Correction

The rapid increase of semiconductor technology in electrical systems has led to a phenomenon known as 'Harmonics'. Solid-state electronic devices and other non-linear electronic loads that alter or control electrical power produce harmonics. Harmonics is referred to as the frequencies that are integer multiples of the fundamental line frequency of 60Hz. These non-linear loads include: adjustable speed drives, programmable controllers, induction furnaces, computers, and uninterruptible power supplies.

Linear loads

Linear loads occur when the impedance is constant; then the current is proportional to the voltage -- a straight-line graph, as shown in Figure below. Simple loads, composed of one of the elements do not produce harmonics.

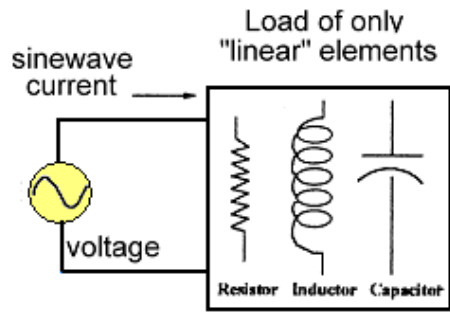
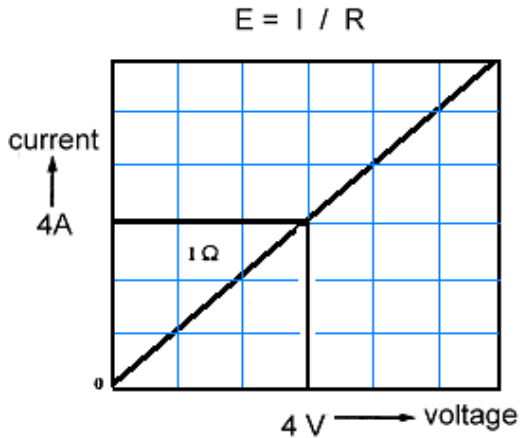

Non-linear loads

Non-linear loads occur when the impedance is not constant; then the current is not proportional to the voltage -- as shown in Figure below. Combinations of the components normally create non-linear loads and harmonics.

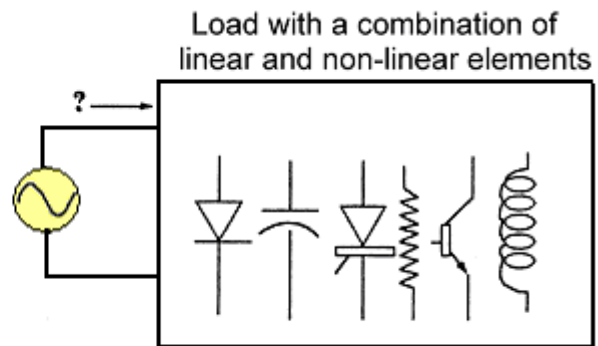
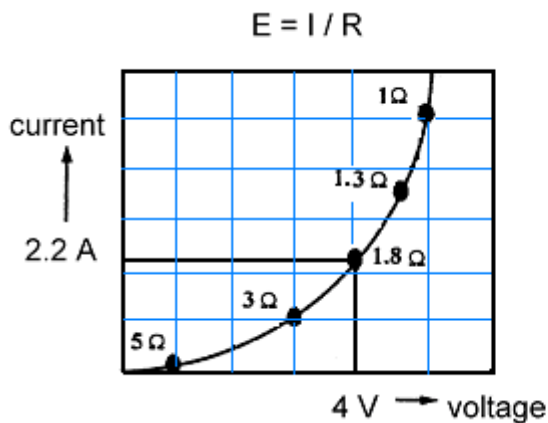

The Cause:

The non-linear loads (electronic systems) dramatically increase harmonic noise on the line side of the power distribution plant, which impacts the whole electrical distribution system.

Typical examples of non-linear loads (harmonic sources) are:

Electronic Switching Power Converters

- ✓ Computers
- ✓ Uninterruptible power supplies (UPS)
- ✓ Solid-state rectifiers
- ✓ Electronic process control equipment, PLC's, etc

- ✓ Electronic lighting ballasts, including light dimmer
- ✓ Neon SCR controlled equipment
- ✓ Reduced voltage motor controllers
- ✓ DC drives

Arcing Devices

- ✓ Discharge lighting, e.g. Fluorescent, Sodium and Mercury vapor
- ✓ Arc furnaces
- ✓ Welding equipment
- ✓ Electrical traction system

Ferromagnetic Devices

- ✓ Transformers operating near saturation level
- ✓ Magnetic ballasts (Saturated Iron core)
- ✓ Induction heating equipment
- ✓ Chokes

Appliances

- ✓ TV sets, air conditioners, washing machines, microwave ovens & vacuum cleaners
- ✓ Fax machines, photocopiers, printers

The Effect:

Harmonics have detrimental effect on the electrical power system in a facility. Overheated neutrals, hot circuit breakers, unexpected breaker tripping, dangerously hot transformers, unexplainable equipment malfunctions, spurious system lockup, and more are now common problems in many facilities. These problems can cause financial losses through added maintenance cost, staff downtime and interrupted production.

Signs of Harmonic Distortion Problems

- ✓ Overheating of motors and transformers
- ✓ Frequent tripping of circuit breakers
- ✓ Frequent fuse blowing
- ✓ Capacitor failures
- ✓ Overloading of transformer neutrals

- ✓ Telephone interference
- ✓ Disoperation of motor variable-speed drives
- ✓ PLC and computer failures – “frozen” screens
- ✓ Electric component & Insulation failures
- ✓ Severe lamp flicker
- ✓ Failure or malfunctioning of computers, motor drives, lighting circuits and other sensitive loads

If any of these conditions exist in your facility an analysis of your system will pinpoint the problem.

Harmonics and Power Factor Capacitors

With non-linear loads it is extremely difficult to correct for poor power factor without increasing existing harmonic distortion thereby trading one problem for another. The simple answer is to treat both problems simultaneously.

The harmonics lead to a higher capacitor current, because the higher frequencies are attracted to the capacitor. The impedance of the capacitor decreases as the frequency increases. If the frequency of such a resonating circuit is close enough to a harmonic frequency, the resulting circuit amplifies the oscillation and leads to immense over-currents and over-voltages.

Capacitors themselves do not generate harmonics, but under certain conditions they can amplify existing harmonics. Necessary precautions must be undertaken when selecting the capacitors. If capacitor is installed in a circuit with harmonics, normally it should be equipped with 6% series reactor. For circuit with significant 5th harmonic, it should be equipped with 8% series reactor. For the circuit with 3rd harmonic, like arc furnace, it should be equipped with 13% series reactor. For the capacitor installed as non-fixed use, it should be equipped with 6% series reactor. If the capacitor is equipped with reactor, its rated voltage should be increased 15% - 20% to insure safety and extend lifetime of capacitor.

To minimize the occurrence of harmonic resonance, the resonant harmonic of the system including the capacitor should be estimated. The resonant frequency can be calculated by:

$$h = \sqrt{\frac{KVAsc}{KVAR}}$$

Where

h = calculated system harmonic

KVA_{sc} = short circuit power of the system

$KVAR$ = rating of the capacitor

In three-phase, low voltage systems, harmonic values of 5, 7, 11, 13, 17, 19 etc should be avoided as they correspond to the characteristic harmonics of non-linear loads. This includes all of the odd harmonics, except for the multiples of 3. Examples of such devices are variable-speed and variable-frequency ac drives, dc drives, three-phase power-controlled furnaces and many other types of industrial equipment.

In single-phase, low-voltage systems, generally exhibit the following harmonics: 3, 5, 7, 9, 11, 13 etc. Note that this includes all of the odd harmonics. Examples of such devices are those usually powered by 'switch mode power supplies', which include personal computers, fluorescent lighting, and a myriad of other equipment found in the modern office. It also includes equipment found in hospitals, TV and radio stations, and control rooms of large processing plants. The harmonics from these devices are generally richest at the third harmonic and continually decrease as the harmonic number increases.

The Options to Reduce Harmonics:

Harmonic levels that exceed the recommended values set forth by IEEE 519 1992 should be addressed through harmonic filtering. Failure to address these harmonic issues may lead to problems on the electrical distribution system, such as those detailed above. Active Harmonic Power Correction Filters is a solution. These sense the critical portions of "dirty" power and inject a correcting element to clean the power. By truly canceling the harmonic component, the true fundamental becomes the only component that is reflected back to the line.

Once identified the resonant harmonics can be avoided in several ways:

1. Change the applied KVAR to avoid unwanted harmonics

Although this is the least expensive way to avoid resonant harmonics, it is not always successful because typically some portion of the applied KVAR is switched on and off as load conditions require. The calculation of system harmonics should be repeated for each level of compensation. Adjusting the size of the capacitor(s) may be necessary to avoid the harmonic values.

2. Add harmonic filters

In order to filter harmonics at a specific site, tuned harmonic filters can be applied. A capacitor is connected in series with an inductor such that the resonant frequency of the filter equals the harmonic to be eliminated. Tuned filters should never be applied without a detailed

analysis of the system. The currents expected to flow in the filter are difficult to predict and are a complex function of the system and load characteristics.

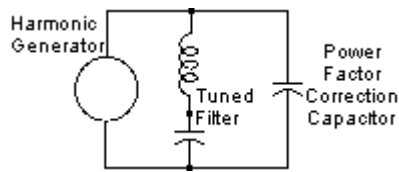

3. Add blocking inductors

Inductors added to the lines feeding the capacitor can be sized to block higher than 4th harmonic currents. This method protects the capacitor from the harmonics but does not eliminate the harmonics from the system. A system study is required to determine correct ratings for the capacitor and inductors.

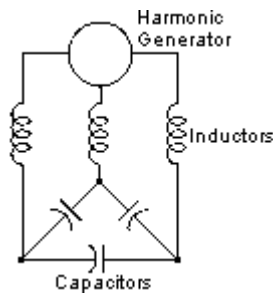

Harmonic Limits in Electric Power Systems (IEEE 519 1992)

The harmonic voltage limitations set forth by IEEE 519 1992 are:

- 1) Maximum Individual Frequency Voltage Harmonic: 3%
- 2) Total Harmonic Distortion of the Voltage: 5%

Harmonic limitations have been established by IEEE 519 1992 for the following reasons:

- To limit the damage to power factor correction capacitors and harmonic filter systems caused by excessive harmonics.
- To prevent series or parallel resonance in the electrical system
- To keep the level of harmonics at the PCC (Point of Common Coupling) from being excessive and distorting the system voltage and damaging other equipment on the system

The PCC is defined as the electrical connecting point or interface between the utility distribution system and the customer's electrical distribution system.

Refer to the latest revision of IEEE 519 for more details on the harmonic current limitations.

Conclusions

Depending on your utility and geographic area, a power factor less than 90% will be penalized, and although there are no penalties paid for the level of harmonics, their presence in the system can be far more costly than the Power Factor penalties. System harmonics should be considered when applying power factor correction capacitors.

Active Harmonic Filters with power correction can

- ✓ Reduce energy costs
- ✓ Increase personnel performance and productivity
- ✓ Create energy savings from 5% to 20%
- ✓ Avoid utility penalties up to an additional 20%
- ✓ Create an economic payback in 1.5 to 3.0 years

Some Questions & Answers about power factor

Q. What is power factor and why is it important?

A. Simply stated, power factor is the percentage of consumed power (KW) versus supplied power (KVA). This is important because a low power factor can waste energy, result in inefficient use of electrical power, and often result in higher energy bills.

Q. Do I have a power factor problem?

A. If you have commercial or industrial premises using more than 75 KW of power and operate a number of electric motors, then indeed you may have a power factor problem. The extent of the problem will depend upon the ratio between the inductive load and the resistive load, and also on the nature of the inductive load.

Q. Is my power factor costing me money?

A. This depends on how bad your power factor is and how your utility company charges for its electricity.

Q. How do I know what my power factor is?

A. In those areas where a power factor penalty is applied, the information relative to the power factor should be contained on the electricity bill. It is advisable to have digital power factor meters installed at your substations, for determining load conditions necessary for designing a practical power factor correction scheme.

Q. How do I know if Power Factor Correction Capacitors will benefit me?

A. Power Factor Correction Capacitors will improve the energy efficiency of any electrical system, but a reduction in your power bill is only available where a power company charges a power factor penalty. Typically the penalty takes the form of a KVA Demand charge.

Q. Our utility company does not have a penalty for low power factor, so why should I worry?

A. No one gets a free ride. The costs of low power factor are most obvious to the utility company who are the aggregate recipients of their user's low power factor. On a smaller scale, the user can enjoy the same cost savings and benefits of power factor correction. The user has his own distribution, switch gears and transformers that must reflect the added capacity to carry reactive power.

Q. Will I get increased benefits if I add an excessive amount of correction?

A. Definitely not- too much capacity on the line (leading power factor) is bad. Under certain conditions dangerously high transient voltages may prevail on the power lines at points far removed from the actual load. Over compensation will adversely affect lighting systems and other machinery and equipment.

Q. How do I choose the correct amount of correction for my application?

A. There are different ways to arrive at the correct amount of KVAR for a given application depending on the information available to you. The IEEE provides standard tables that allow you to choose a KVAR rating for individual motors based on horsepower and RPM rating. Additionally, some motor manufacturers recommend a maximum KVAR rating. Also, the required KVAR can be calculated if you have the following information: Current power factor, desired power factor, and total KW input.

Q. If I correct my power factor, will I improve efficiency?

A. Not directly. It must be remembered that efficiency is the ratio of output power/input power whereas power factor is the ratio of actual power/apparent power. The two are not directly related.

Q. Our plant is heated electrically and we do only light assembly work. Can we be penalized for low power factor?

A. Not likely, except in the case of heat pumps and blower motors to circulate the heat, electric heat is essentially a resistive load. Magnetic fields are not associated with resistive loads: consequently, the power factor would be unity or 100%.

Q. Does it make a difference where in the system one connects power factor correction capacitors?

A. That depends on whom you ask. The utility company is only concerned that the power factor correction be on the user side of the watt-hour meter. It is often to the user's advantage to correct power factor at each load.

Q. Why should power factor be corrected at the load?

A. The user reaps the same advantages as the utility company for high power factor only on a smaller scale. Also, if each load has been corrected, the power factor remains relatively constant since in plants loads are switched on and off and the dangers of over-correction do not exist. If however, power factor has been corrected at the service entry, system power factor can make relatively wide swings as heavy loads are switched on and off.

In providing for power factor correction it should be remembered that distribution boards and circuits can carry a greater useful load if the capacitors are installed as near as possible to the source of the low power factor. For this reason either bulk or individual correction, rather than correction at the intake point, can be justified.

Q. What is the difference between fixed and automatic Power Factor Correction Capacitors?

A. There are two types of Power Factor Correction Capacitors: Fixed and Automatic.

Automatic capacitors are also known as switched capacitors. Automatic capacitors vary the amount of correction (KVAR) supplied to an electrical system, while fixed capacitors supply a constant amount of correction (KVAR). Automatic capacitors are made up of banks that are

switched off and on by a microprocessor controller based on the plant electrical load at any given time. Automatic capacitors are installed at the main incoming power source, while fixed capacitors are generally installed at individual motor loads throughout a plant.

Q. Which are better, fixed or Automatic Power Factor Correction Capacitors?

A. The answer to this varies with each installation. If you have just a limited number of motors that need correction, it would be advisable to put a fixed capacitor at each motor. If you have a large plant with varying loads and numerous motors, an automatic capacitor may be better. Other factors to consider are maintenance and "down-time". A fixed capacitor requires less maintenance and if the unit goes down, you have not lost all of your correction abilities. If you need to replace or work on an automatic capacitor, it may require taking the whole plant down or losing all of your correcting ability for a length of time. Additionally, capacitors cannot be directly connected to some equipment.

Q. Should capacitors used for bulk power factor correction be controlled manually or automatically?

A. Manually controlled capacitors are normally employed for loads which are too small to warrant splitting the total capacitance required, or where high diversity of motor load makes individual correction uneconomic. Manual control can only be justified technically for continuous process work where minimum switching is required and there is sufficient reactive KVA available in the circuit continuously to warrant the capacitors being connected all the time.

Q. In our facility, we have many small machine motors; should each machine be corrected?

A. In this case, it would probably be more advantageous to correct at the branch circuit since smaller capacitor units have higher price per KVAR correction. In general, motors of 10 hp or more are corrected individually, whereas motors are often corrected in groups.

Q. If I decide to install Power Factor Correction Capacitors, what will my payback time be?

A. For customers who are paying a penalty, generally the payback time can be as little as six months or as much as two years. This depends on the billing structure of your utility.

Q. Do fluorescent lamps contribute to low power factor?

A. Yes and no. Fluorescent lamps do use inductive devices-ballasts-but most lamp manufacturers correct for power factor in the individual fixture. With incandescent bulb power factor is not a problem.
